

FLOW-MICROCALORIMETRIC INVESTIGATIONS ON THE RELATIONSHIP BETWEEN HEAT PRODUCTION AND LIGHT EMISSION OF PHOTOBACTERIUM PHOSPHOREUM

J. HARTUNG

Institute for Animal Hygiene of the Hannover School of Veterinary Medicine, Bünteweg 17p, 3000 Hannover 71, FRG

SUMMARY

A flow microcalorimeter and two different photo detectors are used to monitor the heat production and the light emission of growing cultures of *Photobacterium phosphoreum*, respectively. Heat production of bacteria is considered as a general indicator of the function and intensity of the bacterial metabolism. Light production is a special property of luminous bacteria. In the Microtox(R)-test the light emission of *P. phosphoreum* is used to evaluate the toxicity of water polluting compounds.

This study shows that the light emission of a growing culture of *P. phosphoreum* does not run parallel with the heat production. The light emission starts when the logarithmic growth phase of the bacteria is already far advanced. During the microcalorimetric lag-phase even a decrease of the light emission of the inoculated bacteria can be observed. Referred to the Microtox(R)-test it has to be noted that the test is run while the enzymatic system of the bacteria which is responsible for their luminescence is not active. The term "toxic" should be used with restriction in connection with this test.

INTRODUCTION

Photobacterium phosphoreum is a bioluminescent bacterium. This property of light emission is used e.g. in the Microtox(R)-test in order to test and evaluate the biological effect of water polluting compounds (ref.3, ref.9, ref.2). The test is based on the assumption that a decrease of the light emission of the test bacteria under the influence of a test substance indicates an adverse effect of the compound tested. Compounds which decrease the light emission in this way are called toxic in respect to the test, although the light emission represents a marginal metabolic function of the test organism, only. This is in contrast to other tests like the cell multiplication test (ref.1), the motility test with *Spirillum volutans* (ref.4) or microcalorimetric test procedures (ref.6) all of which observe complex metabolic pathways of the test bacteria to evaluate adverse effects. It still

appears doubtful whether a decrease of the light emission of *P. phosphoreum* indicates an inhibition of the energy metabolism, respiration, or phosphorylation (ref.10, ref.8). Adenosine triphosphate (ATP) is an essential source of energy for the light emitting reactions but there is still uncertainty concerning several steps in the metabolism of bioluminescence (ref.5). Few results are available on the relationship of metabolic activity and light emission of photobacteria.

Microcalorimetric investigations on broth cultures of *Photobacterium phosphoreum* were done in this study. A flow microcalorimeter was used in order to record the metabolic activity of the culture by its heat production. At the same time a photo detector registered the light emission.

MATERIALS AND METHODS

A flow microcalorimeter (LKB Instruments, Bromma, Sweden) of the heat conduction type (e.g. ref.11) equipped with a flow-through-chamber of a volume of 0.7 ml was used. The sensitivity was found to be 59.8 $\mu\text{V}/\text{mW}$. The operating temperature of the flow microcalorimeter was 20°C. The resulting heat flow was recorded as power-time-curves by means of a two-channel compensation recorder. The input voltage was set at 100 mV, the paper speed at 3 cm/h.

The light emission of the bacteria was monitored by two photo detectors of different sensitivity. The less sensitive detector consisted of a silicon diode (called: photo detector), the second detector included a photo multiplier. The resulting signals were traced by the second channel of the recorder described above. Depending on the light intensity of the culture and the sensitivity of the detector the input voltage (V) was reduced or amplified in order to keep the deflection of the recorder within the expected limits. Therefore arbitrary units were used in this case.

Lyophilized batches of *Photobacterium phosphoreum* were purchased from Beckman Instruments Inc., Carlsbad, Calif., US, subcultivated, and grown in liquid medium as described by KREBS (ref.7). This medium was used for preparing the inocula and for performing the tests. Overnight-cultures (18 h) were used as inocula.

The investigations were run as follows: A growth vessel

containing 500 ml of liquid medium is kept at a temperature of 20°C in a water bath. The medium is stirred with an electromagnetic stirrer. The broth is continuously pumped both through the flow microcalorimeter (20 ml/h) and through the photo detector (50 ml/h) with the aid of two peristaltic pumps (Micro Perpex Typ 2132, LKB, Bromma, Sweden). The resident time of the broth is about 6 min in the flow microcalorimeter and 30 s in the photo detector. After a baseline is established the test is started by inoculating the medium with an aliquot of the over-night culture of *Photobacterium phosphoreum* resulting in a concentration of bacteria of about 3×10^5 CFU/ml (CFU = colony forming unit). A schematic diagram of the test set-up is given in Figure 1.

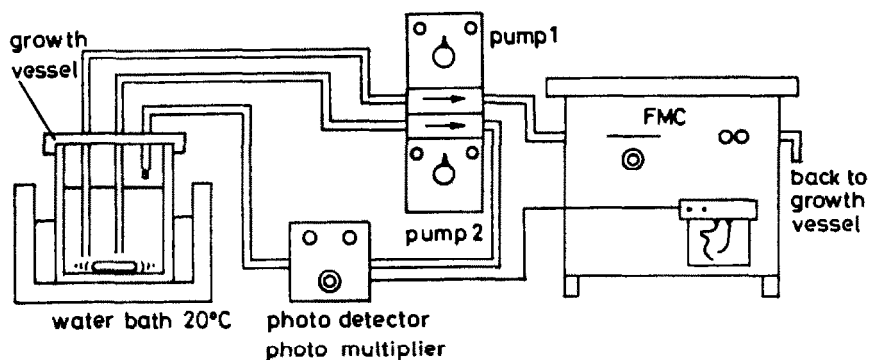

Fig. 1. Schematic diagram of the experimental set-up.
FMC = flow microcalorimeter.

RESULTS

Figure 2 shows the power-time-curve (heat flow) of *Photobacterium phosphoreum* in comparison to the light emission of the culture grown over 20 h. The heat production is measured with the aid of the flow microcalorimeter, the light output by means of the silicon detector (photo detector).

After a lag-phase of about 2 1/2 h the power-time-curve increases and reaches a first peak after about 10 h. Then the power-time-curve shows a short decrease and reaches a second peak about 12 to 13 h after inoculation which is again followed by a decrease. The p-t-curve remains on a constant heat production level of about 25 μ W for another 5 to 6 h. After 20 h the experiment was stopped. The development of the light emission is shown (dotted line, Figure 2) in comparison. The first light emission

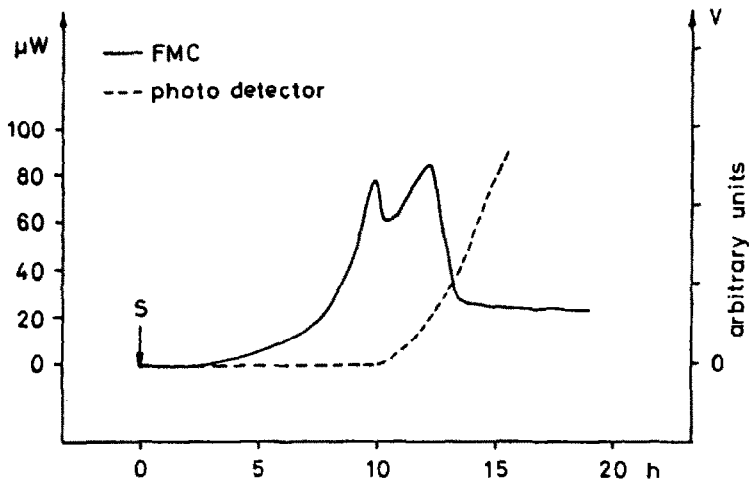

Fig. 2. Comparison of the heat production (μW , FMC = flow microcalorimeter) and the light emission (V; photo detector, silicon diode) of a growing liquid culture of *Photobacterium phosphoreum*. S = inoculation.

which can be registered by the photo detector occurs about 10 h after inoculation. At this time the heat production has already reached its first peak.

When using the more sensitive photo multiplier, the pattern of the light emission differs as shown in Figure 3. Initially, a small amount of light is emitted by the bacteria after inoculation. It decreases within 3 h below the detection level of the photo multiplier. Light emission increases again after about 8 to 9 h. Within 1 to 2 h the light emission increases to such a degree that the used photo multiplier shows overflow even at highest attenuation.

DISCUSSION

The results show that the light emission of a growing culture of *Photobacterium phosphoreum* starts when the logarithmic growth phase of the bacteria is already far advanced. It seems that there is no direct parallelity between growth and light emission. On the contrary, during the microcalorimetric lag-phase (time between inoculation of the bacteria and the first measurable amount of heat flow) when the heat production of the bacteria in the culture is still below the detection threshold of the micro-

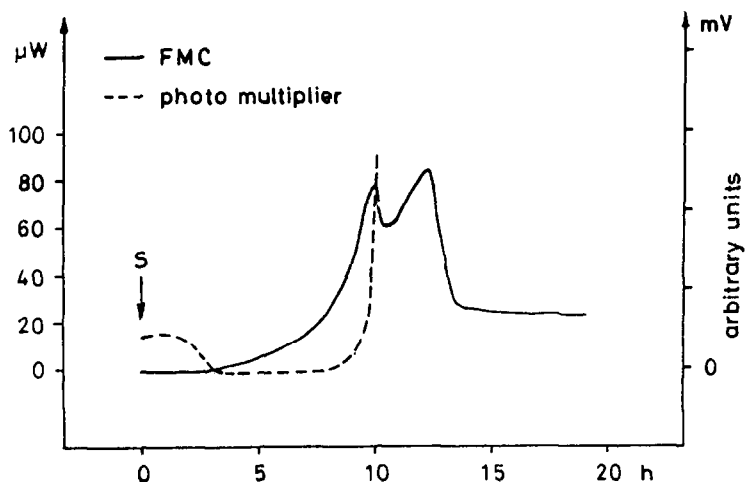

Fig. 3. Comparison of the heat production (μW , FMC = flow microcalorimeter) and the light emission (mV, photo multiplier) of a growing liquid culture of *Photobacterium phosphoreum*. S = inoculation.

calorimeter, even a decrease of the light emission can be observed. No measurable amounts of light can be observed for several hours by means of our equipment. Afterwards the light production is activated again and increases rapidly. The different slopes of the curves in Figure 2 and 3, respectively are caused by the different sensitivities of the two photo detectors. The photo multiplier records the light production of the bacteria which is below the detection threshold of the other photo detector. That is the reason why the curve in Figure 3 increases earlier than in the curve of Figure 2.

NEALSON (ref.8) reported that the light intensity of a luminescent culture of *Photobacterium fischeri* decreased distinctly after dilution for about 3 h. Light emission then increased again, rapidly. The author thinks that a chemical inducer is responsible for this phenomenon. This inducer curtails the synthesis of the luminous system under dilute conditions. The inducer is produced by the bacteria themselves and accumulates in the medium at a constant rate as a function of cell growth. The inducer stimulates the synthesis of the luminous enzyme system after reaching a critical concentration, only.

When these observations are transferred to the Microtox(R)-

test it has to be noted that the test is run while the enzymatic system of the bacteria which is responsible for their luminescence is not active but even decreasing. It might be of advantage for the test that the enzyme system is present in nearly constant amounts while the test is run, even though its level is low and inactive. Further investigations are required in order to estimate whether the inhibition of light emission allows the conclusion that the metabolism of the bacteria is also affected.

"Toxicity" is a term that should be avoided or used with restriction in connection with the Microtox(R)-test - even though its application is suggested by the name of the instrument. The above considerations do not disqualify the Microtox(R)-test which is a very fast method (within 30 min in most cases) for the estimation of the inhibitory effect of water polluting compounds or waste water on the light emission of *Photobacterium phosphoreum*.

ACKNOWLEDGEMENT

The study was supported by the Deutsche Forschungsgemeinschaft Bonn, FRG. The author thanks Dr. G. Klinckmann for revising the English manuscript.

REFERENCES

- 1 G. Bringmann and R. Kühn, Comparison of the toxicity thresholds of water pollutants to bacteria/algae/protozoa in a cell multiplication inhibition test, *Wat. Res.* 14 (1980) 231-241.
- 2 A.A. Bulich, Bioluminescence assay, in: G. Bitton and B.J. Dutka (Ed.), *Toxicity testing using microorganisms*, Vol. I., CRC Press, Boca Raton, Florida, USA, 1986, pp. 57-74.
- 3 B.J. Dutka and K.K. Kwan, Comparison of 3 microbial screening tests, *Bull. Environm. Contam. Toxicol.* 27 (1981) 753-757.
- 4 L.J. Goatcher, A.A. Qureshi and I.D. Gaudet, Evaluation and refinement of the *Spirillum volutans* test, in: D. Liu and B.J. Dutka (Ed.), *Toxicity screening procedures using bacterial systems*, Marcel Dekker, New York, Basel, 1984, pp. 89-108.
- 5 J.W. Hastings, Chemistry and control of luminescence in marine organisms, *Bull. Marine Sci.* 33 (1983) 818-828.
- 6 C. Jolicœur and A. Beaubien, Microcalorimetric studies of microbial metabolism and inhibition, in: G. Bitton and B.J. Dutka (Ed.), *Toxicity testing using microorganisms*, Vol. I., CRC Press, Boca Raton, Florida, USA, 1986, pp. 115-151.
- 7 F. Krebs, Toxizitätstest mit gefriergetrockneten Leuchtbakterien, *Gewässerschutz, Wasser, Abwasser* 63 (1983) 173-230.
- 8 H.K. Nealson, Autoinduction of bacterial luciferase, *Arch. Microbiol.* 112 (1977) 73-79.
- 9 A.A. Qureshi, R.N. Coleman and J.H. Paran, Evaluation and refinement of the Microtox(R) test, in: D. Liu and B.J. Dutka (Ed.), *Toxicity screening procedures using bacterial systems*, Marcel Dekker, New York, Basel, 1984, pp. 1-22.
- 10 W.F. Serat, F.E. Budinger and P.K. Mueller, Toxicity evaluation of air pollutants by use of luminescent bacteria, *Atmosph. Environm.* 1 (1967) 21-32.
- 11 I. Wadsö, Bio-calorimetry, *Trends Biotech.* 4 (1986) 45-51.